

CARCASE CONSTRUCTION-Simple Corners (L Joints)

What is a Carcase?

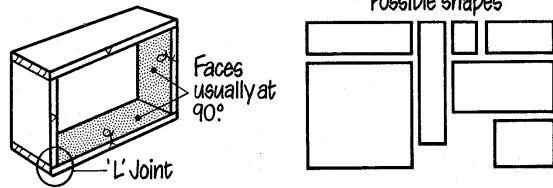

Simple L Joints

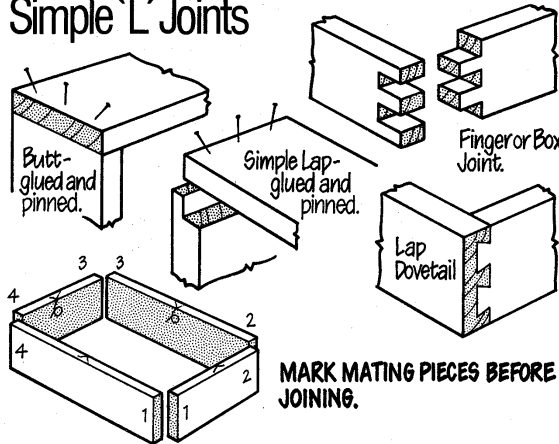

Setting a bevel to a slope of 1:6

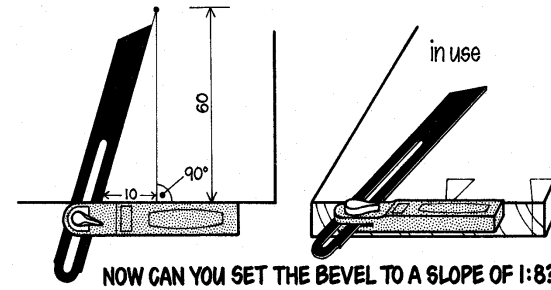

Cutting the tails

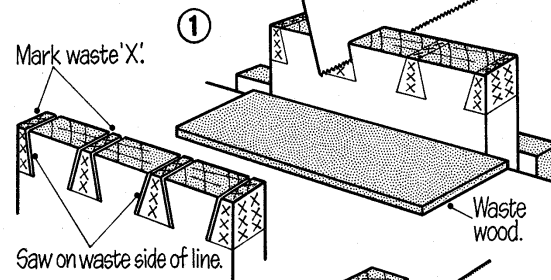

2 REMOVE BULK WASTE with Coping Saw or Chisel.

3 TRIM TO LINE.

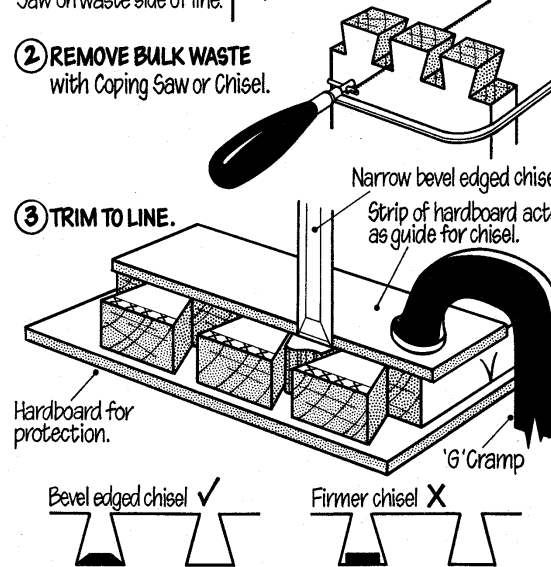

Cutting the pins

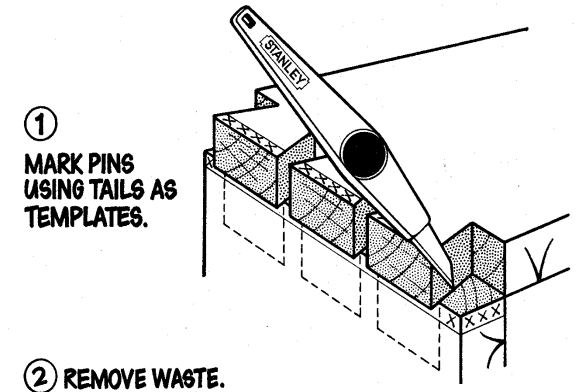

2 REMOVE WASTE.

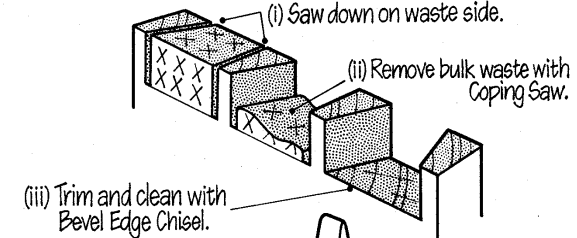

3 ASSEMBLE.

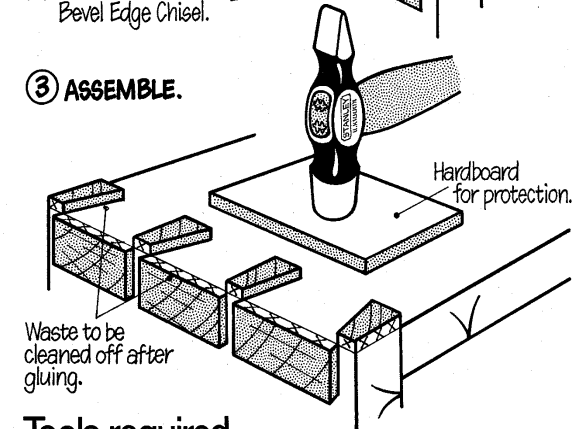

Tools required

MARKING OUT: Pencil, Rule, Knife, Try Square, Bevel.
CUTTING TOOLS: Saw, Coping Saw, Bevel Edge Chisels/ Mallet.
HOLDING AIDS: 'G' Cramp, Vice.
EXTRAS: Waste Wood, Hammer.

Procedure for making a Through Dovetail Joint

