

FRAME CONSTRUCTION - Simple Corners (L Joints)

STANLEY

© Stanley Tools Limited, Sheffield S3 9PD

What is a Frame?

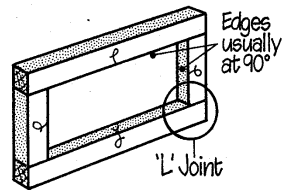

Possible shapes and arrangements.

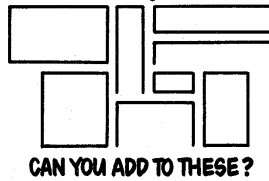

Simple L Joints

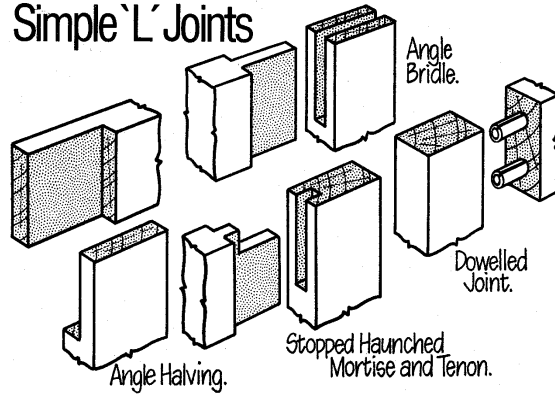

Procedure for making a Through Haunched Mortise and Tenon

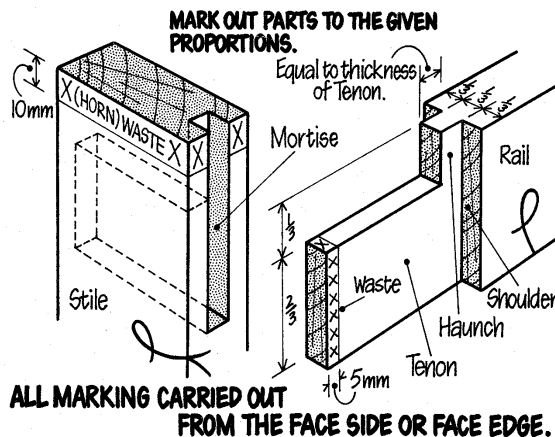

Cutting the Mortise

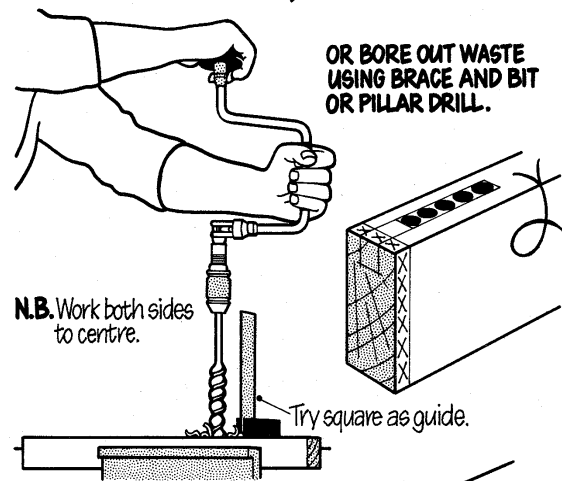
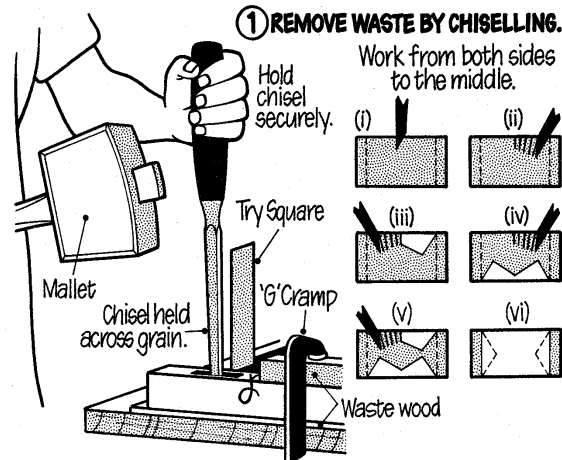

2 CLEAN OUT HAUNCH.

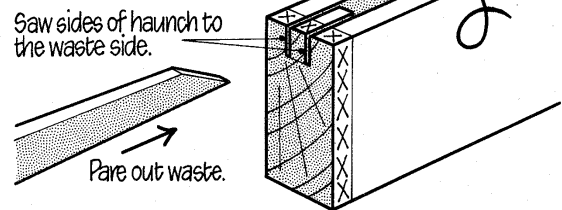

Cutting the Tenon - sawing procedure

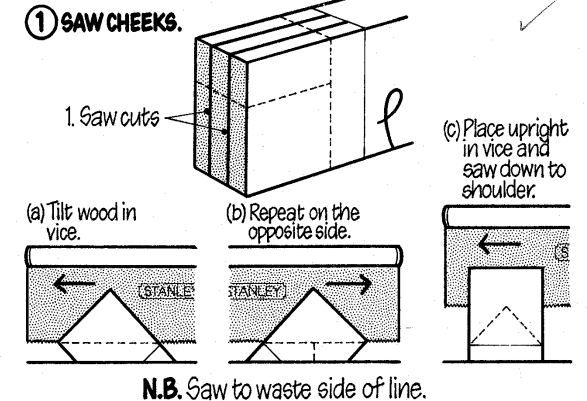

2 SAW WIDTH OF TENON.

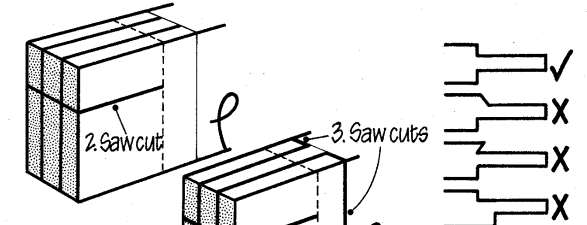

3 SAW SHOULDERS.

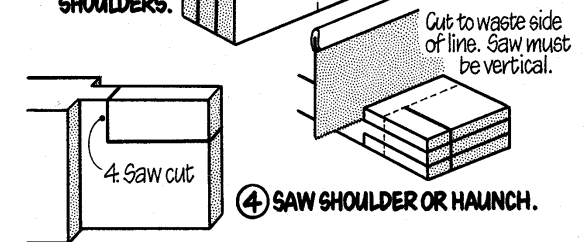

Tools required

- MARKING OUT:** Pencil, Knife, Rule, Try Square, Marking Gauge, Mortise Gauge.
- CUTTING TOOLS:** Chisel/Mallet or Brace and Bit, Saw, Chisels.
- HOLDING AIDS:** G Cramp, Vice, Bench Hook, Holdfast.
- EXTRAS:** Waste wood to protect bench.